

ULTRAPLUS M12-M36

The undercut anchor for exceptionally high loads in cracked and non-cracked concrete – also for shock and seismic loads.

FUNCTION

When the anchor is installed the expansion segments are driven down to the undercut in the drilled hole. The spring pressure automatically expands the segments into the undercut with an audible “click.” This results in a mechanical undercut connection without any expansion pressure. The “positive undercut” allows perfect bearing of the segments and ensures reliable transmission of the load into the concrete.



BENEFITS

- Reliable fixing for high loads in cracked and non-cracked concrete
- High margin of safety due to positive undercutting
- Produced from high strength materials
- The spring automatically compensates for tolerances in the fixture thickness
- Modular design allowing for custom lengths and assemblies
- Reduced edge distances and spacings
- Proven performance history in resisting dynamic loads, shock loads and seismic loads. Expert reports available for these and other applications.



EJOT® High performance fastening with unrivalled global support

CONSTRUCTION

With hex nut, washer, threaded stud and plastic retaining ring



MATERIAL

High strength carbon steel, stainless steel

BASE MATERIAL

Cracked and non-cracked concrete

APPROVAL

ETA-04/0098 – Option 1 – Approved for cracked and non-cracked concrete

LOAD RANGE

Tension: $N_{perm} = 19.0 - 320.2$ [kN] Shear: $V_{perm} = 45.2 - 371.4$ [kN]

PRODUCT RANGE

M12 – M36, carbon steel, zinc plated, HDG, sherardised, stainless steel

CHARACTERISTICS

- Positive undercut anchor with strong mechanical interlock
- Instant loading
- Completely removable
- Through-fix installation
- No expansion forces
- Small edge distances and anchor spacings

APPLICATIONS

- Nuclear power plants
- Industrial plants
- Water treatment plants
- Petrochemical installations
- Steel construction
- Cranes

BENEFITS

- Extremely high tensile and shear capacity
- Custom lengths and assemblies readily available
- Positive undercutting (comparable performance to a cast-in headed stud)

PRODUCT DESCRIPTION

The **ULTRAPLUS** undercut anchor is designed for use in applications where reliability and safety are essential, e.g. for anchoring safety relevant components in nuclear power plants, for industrial plants, conveyor systems, cranes and also for special civil engineering solutions.

The **LIEBIG ULTRAPLUS** was developed to resist very high loads with its unique undercutting technology. After the hole is drilled, a separate undercut is created using the LIEBIG undercutting tool. When the anchor is inserted through the fixture, spring pressure opens the expanding segments.

These lock into the undercut with a clearly audible click. The result is a mechanical interlock without expansion stresses. By applying the specified torque, the fixture is fastened in position. The “positive undercut” allows perfect bearing of the segments and ensures reliable transmission of the load into the concrete.



European technical approval option1

ULTRAPLUS M12-M36

Custom lengths available on request.

ULTRAPLUS Carbon Steel Zinc Plated and Stainless Steel A4

Threaded stud with hex nut and washer

*Available in high strength zinc plated, sherardised, HDG and stainless steel

Approval: ETA-04/0098 – Option 1 for cracked and non-cracked concrete



| Type | Order Code | Thread Size | Diameter x Depth of drilled hole | Max Fixture Thickness | Fixture Hole Diameter | Eff. Embedment Depth | Total Length | Weight (kg/100pcs) | Box Quantity |
|--------------------|--------------|-------------|----------------------------------|-----------------------|-----------------------|----------------------|--------------|--------------------|--------------|
| UP M12-23/140/20 | UP1223140020 | M12 | 23x190 | 20 | 24 | 140 | 220 | 48 | 10 |
| UP M16-30/220/30 | UP1630220030 | M16 | 30x300 | 30 | 32 | 220 | 325 | 123 | 5 |
| UP M20-36/250/50 | UP2036250050 | M20 | 36x330 | 50 | 38 | 250 | 380 | 173 | 5 |
| UP M24-45/280/60* | UP2445280060 | M24 | 45x410 | 60 | 46 | 280 | 460 | 408 | 2 |
| UP M36-67/420/100* | UP3667420100 | M36 | 67x570 | 100 | 68 | 420 | 700 | 1305 | 1 |

*Not included in approval. Also available in HDG, sherardised and stainless steel

INSTALLATION ACCESSORIES

Undercutting tool for core drilling rigs with 1/2" drive



Diamond cutting blade



| Compatible ULTRAPLUS | Order Code | KG/PC |
|----------------------|------------|-------|
| M12 | D23 | 2.6 |
| M16 | D30 | 3.1 |
| M20 | D36 | 4.1 |
| M24 | D45 | 5.1 |
| M36 | D67 | 8.1 |

| Compatible ULTRAPLUS | Order Code | KG/PC |
|----------------------|------------|-------|
| M12 | DE23 | 0.5 |
| M16 | DE30 | 1.0 |
| M20 | DE36 | 1.2 |
| M24 | DE45 | 2.1 |
| M36 | DE67 | 3.3 |

Undercutting tool is available for either purchase or hire.

Installation data

| Thread Size | | | M12 | M16 | M20 | M24 | M36 |
|-------------------------------|-------------------------------|------------|--------------------------|-----|------|------|------|
| Drill hole diameter | d_0 [mm] | | 23 | 30 | 36 | 45 | 67 |
| Drill hole depth | h_1 [mm] | | 190 | 300 | 330 | 410 | 570 |
| Diameter of undercutting | d_1 [mm] | | 35 | 47 | 53.5 | 74 | 105 |
| Undercutting | Δd_{cut} [mm] | | 6 | 8.5 | 8.75 | 14.5 | 19 |
| Clearance hole in the fixture | Through-fix anchorage | d_f [mm] | 24 | 32 | 38 | 46 | 68 |
| | Installation on threaded stud | d_f [mm] | 14 | 18 | 22 | 26 | 39 |
| Width across flats | sw [mm] | | 24 | 36 | 41 | 50 | 75 |
| Installation torque | T_{inst} [Nm] | | 120 (80 Stainless Steel) | 250 | 300 | 790 | 2000 |

ULTRAPLUS INSTALLATION INSTRUCTIONS

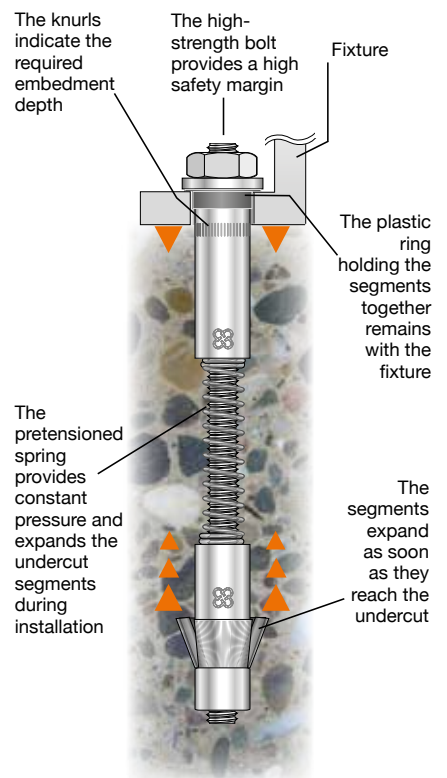
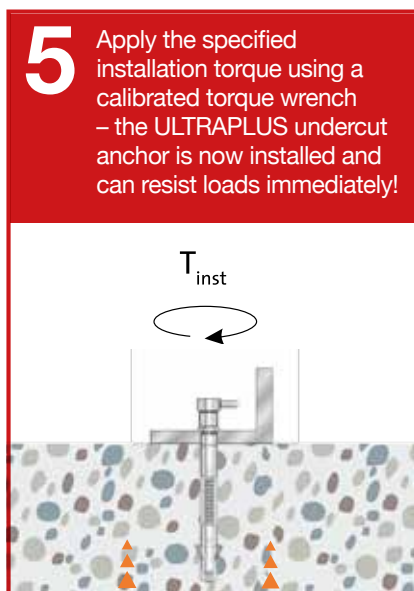
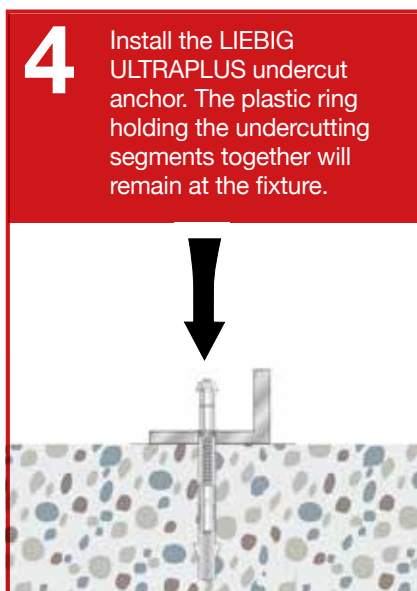
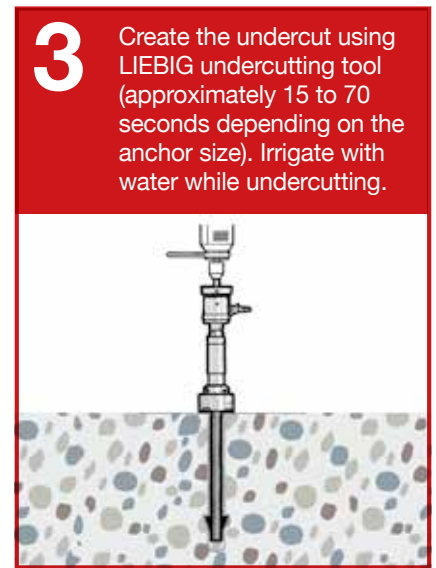

Installed anchor

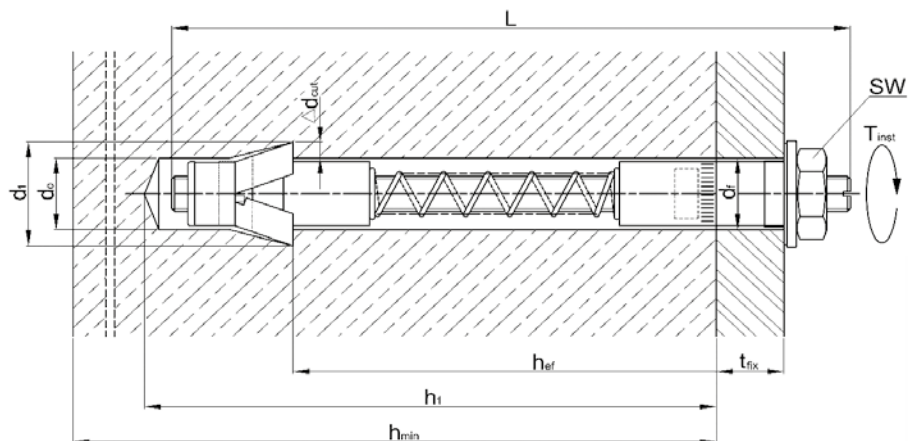

Installation video
now available on the
EJOT UK YouTube
channel

Custom lengths available on request.

ULTRAPLUS Carbon Steel Zinc Plated

Permissible loads for single anchors with no influencing edge distances or spacings. Loads are calculated using partial safety factors from ETAG 001 and the characteristic anchor and installation data from this catalogue. Design calculations shall follow the requirements of ETA-04/0098. Material: Carbon steel zinc plated. (Stainless Steel A4).

| Thread Size | M12 | M16 | M20 | M24 | M36 |
|--------------------------------|----------------|----------------|----------------|----------------|----------------|
| Effective embedment depth (mm) | 140 | 220 | 250 | 280 | 420 |
| Type UP | M12-23/140/... | M16-30/220/... | M20-36/250/... | M24-45/280/... | M36-67/420/... |

Permissible tension loads¹⁾ - Carbon Steel Zinc Plated (Stainless Steel A4)

| N_{perm} | Concrete | Type | [kN] | M12 | M16 | M20 | M24 | M36 |
|------------|------------------------------------|--------|------|-------------|-------------|--------------|---------------|---------------|
| | | | | | | | | |
| | Cracked | C20/25 | [kN] | 19.0 (19.0) | 35.7 (35.7) | 45.2 (45.2) | 80.3 (80.3) | 147.6 (147.6) |
| | | C30/37 | [kN] | 23.2 (23.2) | 43.6 (43.6) | 55.2 (55.2) | 98.0 (98.0) | 180.0 (180.0) |
| | | C40/50 | [kN] | 26.9 (26.9) | 50.4 (50.4) | 63.8 (63.8) | 113.3 (113.3) | 208.1 (208.1) |
| | | C50/60 | [kN] | 30.1 (29.9) | 56.4 (56.3) | 71.5 (71.5) | 124.5 (124.5) | 228.7 (228.7) |
| | Non-Cracked Concrete ³⁾ | C20/25 | [kN] | 28.6 (28.6) | 45.2 (45.2) | 66.7 (66.7) | 111.9 (111.9) | 206.6 (206.6) |
| | | C30/37 | [kN] | 34.9 (29.9) | 55.2 (55.2) | 81.3 (81.3) | 136.5 (126.1) | 252.0 (252.0) |
| | | C40/50 | [kN] | 40.3 (29.9) | 63.8 (56.3) | 94.0 (87.5) | 157.8 (126.1) | 291.3 (291.8) |
| | | C50/60 | [kN] | 43.4 (29.9) | 71.5 (56.3) | 105.3 (87.5) | 173.5 (126.1) | 320.2 (291.8) |

Permissible shear loads²⁾ - Carbon Steel Zinc Plated (Stainless Steel A4)

| V_{perm} | Concrete | Type | [kN] | M12 | M16 | M20 | M24 | M36 |
|------------|------------------------------------|--------|------|-------------|-------------|---------------|---------------|---------------|
| | | | | | | | | |
| | Cracked | C20/25 | [kN] | 45.2 (48.3) | 81.0 (85.9) | 109.5 (123.5) | 160.6 (160.6) | 295.1 (295.1) |
| | | C30/37 | [kN] | 45.2 (48.3) | 81.0 (85.9) | 109.5 (123.5) | 164.6 (196.0) | 360.0 (360.0) |
| | | C40/50 | [kN] | 45.2 (48.3) | 81.0 (85.9) | 109.5 (123.5) | 164.6 (196.0) | 378.6 (416.1) |
| | | C50/60 | [kN] | 45.2 (48.3) | 81.0 (85.9) | 109.5 (123.5) | 164.6 (196.0) | 378.6 (445.5) |
| | Non-Cracked Concrete ³⁾ | C20/25 | [kN] | 45.2 (48.3) | 81.0 (85.9) | 109.5 (123.5) | 164.6 (196.0) | 378.6 (414.0) |
| | | C30/37 | [kN] | 45.2 (48.3) | 81.0 (85.9) | 109.5 (123.5) | 164.6 (196.0) | 378.6 (445.8) |
| | | C40/50 | [kN] | 45.2 (48.3) | 81.0 (85.9) | 109.5 (123.5) | 164.6 (196.0) | 378.6 (445.8) |
| | | C50/60 | [kN] | 45.2 (48.3) | 81.0 (85.9) | 109.5 (123.5) | 164.6 (196.0) | 378.6 (445.8) |

Permissible bending moments^{1) 5)} - Carbon Steel Zinc Plated (Stainless Steel A4)

| M_{perm} | [Nm] | M12 | M16 | M20 | M24 | M36 |
|------------|------|-------------|---------------|---------------|---------------|-----------------|
| | | 62.4 (56.4) | 158.1 (142.9) | 309.0 (278.7) | 534.5 (481.1) | 1881.7 (1693.5) |

Spacings, edge distances and member thicknesses

| Parameter | Symbol | [mm] | M12 | M16 | M20 | M24 | M36 |
|--|------------|------|-----|-------------------|-------------------|-----|------|
| Effective embedment depth | h_{ef} | [mm] | 140 | 220 | 250 | 280 | 420 |
| Characteristic spacing ⁴⁾ | $s_{cr,N}$ | [mm] | 420 | 660 | 750 | 840 | 1260 |
| Minimum spacing | s_{min} | [mm] | 140 | 220 | 250 | 280 | 420 |
| Characteristic edge distance ⁴⁾ | $c_{cr,N}$ | [mm] | 210 | 330 | 375 | 420 | 630 |
| Minimum edge distance | c_{min} | [mm] | 140 | 220 | 250 | 280 | 420 |
| Minimum member thickness | h_{min} | [mm] | 240 | 360 | 400 | 500 | 700 |
| | | | — | 330 ⁶⁾ | 360 ⁶⁾ | — | — |

1) The permissible loads have been calculated using the partial safety factors for resistances stated in the ETA-approval and a partial safety factor for actions of $\gamma_F = 1.4$. The permissible loads are valid for unreinforced concrete and reinforced concrete with a rebar spacing $s \geq 15$ cm and reinforced concrete with a rebar spacing $s \geq 10$ cm if the rebar is 10 mm or smaller.

2) The permissible shear loads are based on a single anchor without influencing concrete edges. For shear loads applied close to an edge ($c \leq 10 h_{ef}$ or $60 d$) concrete edge failure must be checked per ETAG 001, Annex C, design method A.

3) Concrete is considered non-cracked when the tensile stress within the concrete is $\sigma_L + \sigma_n \leq 0$. In the absence of detailed verification $\sigma_n = 3$ N/mm² can be assumed (σ_L equals the tensile stress within the concrete as a result of external loads, forces on anchors included).

4) If spacings or edge distances become smaller than the characteristic values (i.e. $s \leq s_{cr,N}$ and/or $c \leq c_{cr,N}$) a calculation per ETAG 001, Annex C, design method A must be performed. For details, see ETA-04/0098.

5) The permissible bending moments are only valid for the threaded stud (e.g. in case of a distance mounting).

6) This h_{min} only applies when the remote face of the concrete is inspected to ensure there has been no break-through as a result of drilling. Otherwise $h_{min} = 360$ mm (M16) and $h_{min} = 400$ mm (M20).



EJOT UK Limited,
Hurricane Close,
Sherburn Enterprise Park,
Sherburn-in-Elmet,
Leeds LS25 6PB.
United Kingdom

Tel: +44 1977 68 70 40

Fax: +44 1977 68 70 41

Email: liebig@ejot.co.uk

www.ejot.co.uk



The ORIGINAL Anchoring Technology

www.liebig-anchor.co.uk

www.liebig-safetybolt.co.uk

www.liebig-ultraplus.co.uk

www.liebig-superplus.co.uk